

3/4"-10NC-2 X 2' LONG HEX HEAD BOLT, LOCKWASHER AND FLATWASHER ALL STAINLESS STEEL - PASSIVATED 4 OF EACH REQUIRED

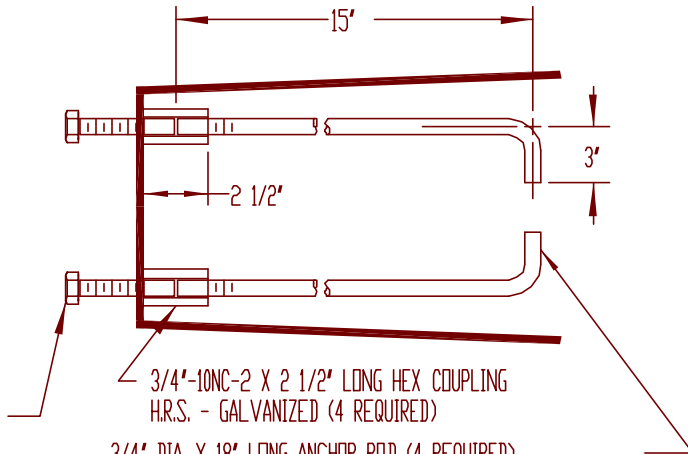

3/4' DIA. X 18' LONG ANCHOR ROD (4 REQUIRED)
ANCHOR ROD PER ASTM A576 STEEL WITH 55,000 PSI YIELD STRENGTH. TOP 6' OF ROD TO BE GALVANIZED PER ASTM A153.

NOTE:

1. - USE 4043 WELD WIRE.
2. - 6063 ASSEMBLY WITH .375 WALL OR LESS TO BE HEAT-TREATED TO T6 TEMPER AFTER WELDING.

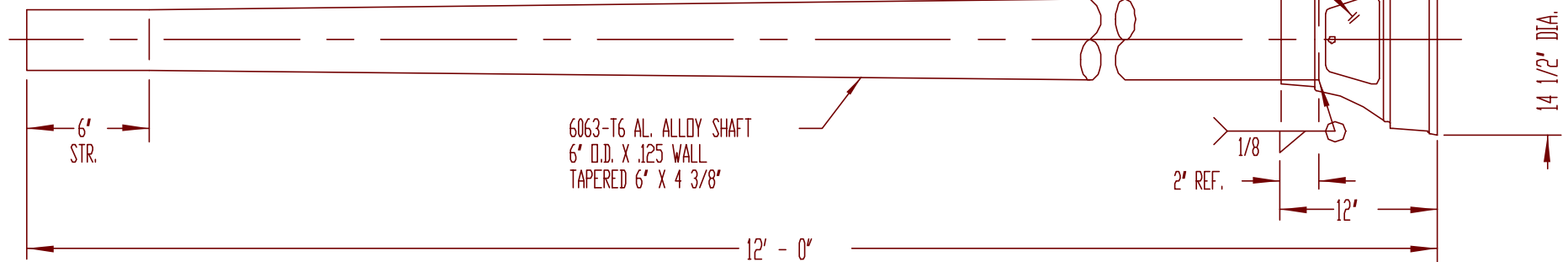

6063-T6 AL. ALLOY SHAFT
6' O.D. X .125 WALL
TAPERED 6' X 4 3/8"

(P&K)

HEX NUT - 2 REQUIRED
1/4"-20NC-2
ROUND HEAD MACHINE SCREW
1/4"-20NC-2 X 1 1/2" LONG
HAS-1283

LOCKWASHER, 1/4" BOLT
FLATWASHER, 1/4" BOLT
2 REQUIRED

ELECTRICAL GROUNDING DETAIL
(ALL HARDWARE STAINLESS STEEL - PASSIVATED)

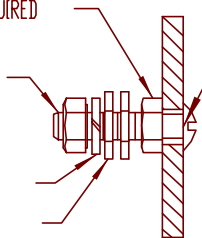

DRILL & TAP
1/4"-20NC-2
THRU BASE WALL
OPPOSITE DOOR
OPENING

ALTERATIONS					MATERIAL	P&K POLE PRODUCTS 84 Foundry St., Newark, N.J.		
ALT	REVISION	DATE	BY	CHK	STOCK SIZE	TITLE		
						SP644512001P-10		
					FINISH OR TEMPER	DR.	JBP.	05-12-74
						DA.		
						APP.		
					CUSTOMER	B-61328-1		
					NEW JERSEY DEPT. OF TRANSPORTATION	SCALE	NONE	